

U120-LR v2 ESC MANUAL

Disclaimer

Thank you for choosing this product. Please carefully read this manual before using this product. Using this product will indicate you're agreed with the all items in this manual. Please strictly follow these items during usage. We'll not commit any responsibility including but not limited to indirect loss or joint responsibility caused by improper usage, private modification and other faults.

Attention

This part has strong power. High speed running propellers have certain safety risk. User must be older than 18 years and have relative professional knowledge. Before usage, please carefully check if all the components are in good conditions.

Features

Quick response. it will take only 0.25 seconds from starting motor to full speed running.
 Good compatibility and stability with special control algorithm for disc motors.
 Synchronous flow technology, with better throttle linearity and drive efficiency. Further, during deceleration, the ESC will automatically recycle energy and charge the battery reversely for extending flight time.
 With CAN communication interface, it can communicate with flight control in real time.
 IP67 waterproof grade, using potting flame-retardant waterproof process, anti-corrosion shell encapsulation.
 Both control signal interface and main power are fully isolated, safer and more reliable.
 Supports fixed paddle function, including calibration, current and angle settings.

Protection Function

Short Circuit Protection

When the ESC detects and triggers short circuit protection, it will turn off the output. It will automatically resume and restart after 100ms.

Stalling Protection

Motor stall will trigger stalling protection. ESC will resume after making throttle zero and powering again.

Voltage Protection

Once checking voltage is less than 16V or more than 64V, ESC will alarm and will not start up motor. But it will be out of effect during flying.

Temperature Protection

During flight, if the temperature of the ESC is higher than 125°C, it will generate a fault signal and start reducing the output power to 50% of the maximum value. If the temperature continues to rise to 140°C, the ESC will turn off the output, and the normal output will not be restored until the throttle setting is reset to zero. When the temperature drops to 80°C, the output power of the ESC starts to rise to the maximum value.

Throttle Loss Protection

When the detected throttle signal is lost for more than 2 seconds, the ESC will automatically shut down. After the throttle signal is restored, the ESC will work again.

Start Protection

If the throttle is accelerated for 10 seconds but the motor fails to start, the ESC will turn off the output. In this case, you need to reset the throttle to zero, and then accelerate the throttle to return to normal.

Throttle Stroke Setting

First to connect motor with ESC, then to power on & adjust throttle to top, you will hear sound of Beep-Beep for two times. Then adjust the throttle to lowest, you will hear a sound of Do-Mi-So, that means the throttle stroke has been set successfully.

ESC Connection

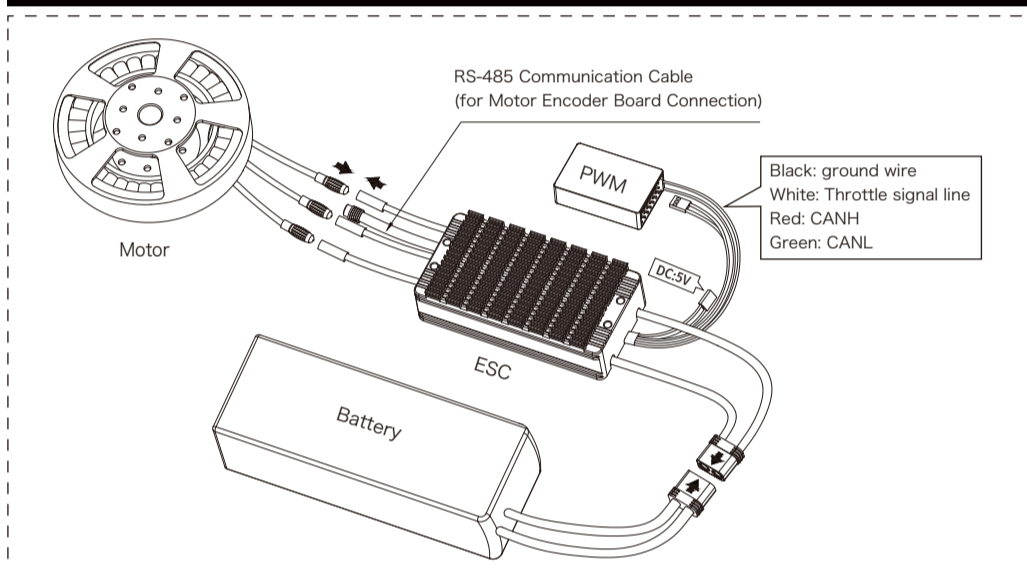

ESC Parameter

Model: U120-LR v2	Battery Section: 5-14S
BEC: 5V/200mA output	Recommended Battery: 12S
PWM Input Signal Voltage: 3.3V/5V(compatible)	Compatible Signal Frequency: 50-500Hz
Online Update: available	Stall Protection: available
Throttle Loss Protection: available	Temp detection: not available
Phase Short Circuit Protection: available	CAN communication: available
Size(L*W*H): 81.8*41.2*23.2mm	Error Signal Output: available
Power Line: 12AWG	Motor Line: 12AWG
Continuous Current: 120A (under good cooling conditions)	Protection Grade: IP67
Current limiting: 120A	
Throttle Pulse Width: default 1050us-1940us, throttle adjustment is available.	
Voltage Protection: available	
Temperature Protection: available	
Speed Signal Output: available	
Weight(without lines): 140g	
Working Environmental Temperature: -20~65 °C	

U120-LR Fixed-Pitch Function User Guide

1.Introduction

The fixed-pitch system refers to a propulsion system in which the propeller blade angle remains fixed and unchanged when the motor is stopped

2.Motor Calibration

blade angle to a specified fixed-pitch angle position

Firmware Upgrade | Parameter Settings | Throttle Calibration | Fixed-Pitch Adjustment

Fixed-Pitch Settings

Select Device:

Motor Calibration

Fixed-Pitch Function:

Fixed-Pitch Current: 2A

Fixed-Pitch Angle: 0

Real-Time Angle

0°

Calibration Method: Adjust the propeller blades to the desired fixed-pitch angle → click the Motor Calibration button → wait for the motor calibration to complete.

Note: Motor calibration must be performed again whenever the phase wire sequence is changed.

3.Function Switch

The fixed-pitch function switch can enable or disable the fixed-pitch function.Usage: Click Fixed-Pitch Function → Save Settings.

4.Fixed-Pitch Current

The fixed-pitch current setting allows you to change the maximum current during fixed-pitch adjustment.Usage: Select the appropriate fixed-pitch current → Save Settings.

5.Fixed-Pitch Angle

The fixed-pitch angle setting allows you to directly adjust the propeller blade to a specified angle position.The angle set here is relative, with the motor' s calibrated initial angle serving as the zero-degree reference.By setting the fixed-pitch angle, you can change the propeller angle to the specified position when the fixed-pitch function is enabled.

Usage: Set the desired fixed-pitch angle → Save Settings → wait for the real-time angle to rotate to the set position.

Trouble Shooting

Problem	Alarm	Cause	Solution
Motor can't start after powering on.	Quick noise of beep beep beep...	Throttle is not made zero.	Adjust throttle to bottom
Motor can't start after powering on.	Beep, beep, beep... every 1 second.	Receiver has not throttle output signal.	Check sender and receiver co-work condition, check throttle control lines.
Voltage is less than 16V.	Beep-Beep, Beep-Beep... every 1 second.	Battery voltage is too low.	Change full power battery.
Voltage is more than 64V.	Beep-Beep, Beep-Beep... every 1 second.	Battery voltage is too high	Change proper full power battery.
Temperature is higher than 125°C	Beep-Beep-Beep, Beep-Beep-Beep... every 1 second.	ESC' s temperature is too high	Please cool down the ESC in a ventilated place
The power-on current or short-circuit protection is abnormal	Beep-Beep-Beep-Beep, Beep-Beep-Beep-Beep... every 1 second.	Overload	Replace the appropriate propeller blades