

## 1. Specification

Description	Min.	Normal	Max	Unit
Operating voltage	4.5	5.0	5.5	V
Operating power	0.22	0.335	0.358	W
Light brightness	-	300	-	cd/m2
Display refresh time	-	0.3	-	S
Operating temperature	-20	20	55	°C
Storage temperature	5	20	70	°C
Size (L*W*H)	68.0 * 38.2 * 16.6			mm
Power Combo Set	ESC	Motor	Propeller	Maximum thrust
	PM-UH150	X135-35KV	51*24	60KG
	PM-UH200	X40C30-50KV	47*13	70KG
	PM-UH300	X50C35-40KV	57*19	90KG

## 2. Usage

This PPG Controller is a device used to assist ESC to display and set parameters. This product is connected to the ESC through the CAN bus to display information such as voltage, current, power, ESC temperature, motor temperature, power, and flight altitude. It also has fall protection, high temperature protection, and mode switching functions. It meets the requirements of paramotor pilots to understand the status and information of the ESC and motor. It can make the control of paramotor more convenient, safe and intelligent.

## 3. Displayed information

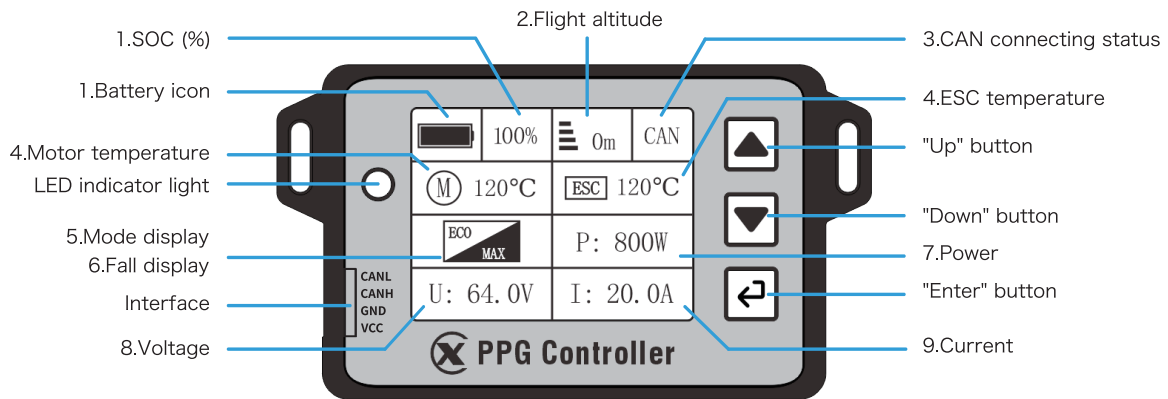

### 1. SOC (%)

SOC is defined as the percentage of the battery remaining charge to the current maximum capacity. Before use it, you need to check whether the set full capacity and number of battery cells are both correct. When the battery is fully charged, please press the "Up" button to reset the power to 100%; and the device will automatically recognize it as full capacity when it is turned on. The displayed remaining capacity is for reference only. Due to the limitation of sampling accuracy, product measurement may deviate from the actual value. Please don't rely too much on it. In addition, when the remaining capacity reaches the set prompt value, the LED light flashes and the remaining capacity percentage flashes at the same time.

### 2. Flight altitude

Before using it, please press the "Up" button and the "Down" button simultaneously for a long time to clear the current flight altitude and calibrate it. When the main interface of PPG Controller displays an altitude lower than 1km, its display unit is m. Such as "999m". When the flight altitude is greater than 1km, it only displays k and ignores the unit "m", such as "1.99k". Under normal use, its accuracy is 1 m. During usage, please keep the vents on the back cover open for ventilation and heat dissipation.

Press the "Up" button for a short time to enter the altimeter detailed interface (it will automatically return if there is no operation for 30 seconds):

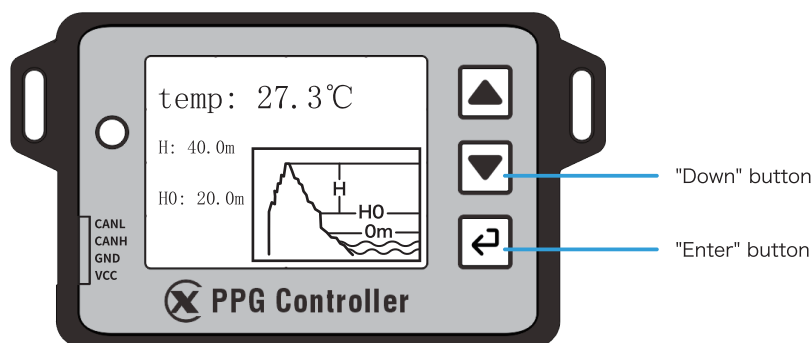

\*As shown in the figure, 0m is the sea level reference and H0 is the take-off altitude. Before setting, the default height of H0 is 0m. H is the flight altitude, which is the height difference between the take-off altitude and the current altitude. In the altimeter detailed interface, you can also long press the "Down" key to set the current altitude as the take-off altitude. It is the same as the calibration function of clearing altitude in the main interface. Short press the "Enter" key in this interface, or wait for 30 seconds without any operation, it will return to the main interface.

**3. CAN connection status**

It displays the CAN connection status. When it displays "CAN", it means the CAN bus is connected at this time. When it displays "CAN" and the icon flashes, it means that the CAN is in a disconnected state and the indicator light will flash.

**4. Motor temperature and ESC temperature:**

There is a temperature sensor inside the ESC that can directly display the ESC temperature. However, if you need to display the motor temperature, you need to correctly install the temperature sensor on the motor according to the user manual of ESC. When the temperature of the ESC and motor reaches the set high temperature protection threshold, it will trigger the high temperature protection. High temperature protection will force the mode to be converted to economy mode at this time, and it will not allow switching modes until the high temperature protection ends. At this time, the LED indicator light flashes, and at the same time, the corresponding temperature part also flashes to facilitate the user to find the cause of the fault faster. The high temperature protection will not end until the temperature drops to the set high temperature protection threshold (minus 25°C). Then, after returning to normal mode, you can switch to "MAX" mode;.

**5. Mode display**

The mode can be set to two modes, "MAX" mode and "ECO" mode. If it displays "ECO MAX", it means economic mode. If it displays "ECO MAX", it means powerful mode. When the "Down" button is long pressed, the mode will switch. During the switching process, the total throttle percentage increases or decreases by 1% every 0.1S; it can switch modes during fall protection, high temperature protection, and low voltage protection.

**6. Fall protection**

The product is normally placed vertically at 90 degrees. When its angle is within the setting range, it is judged as normal. If its angle exceeds the setting range, it will be considered a fall. The default value of pitch angle is 60~135 (60 is a fixed value and cannot be set). The default value of roll angle is -45~45. Within this value, the fall protection throttle is immediately cleared and the LED flashes. At the same time, the mode display position changes to "⚠️", and flashes, indicating fall protection. Mode operation cannot be switched at this time. When the angle returns to the set degree minus 15 degrees for 1S (when it is pitch, it is 60 degrees to the set maximum value minus 15 degrees), it will return to normal. At this time, the total throttle percentage is increased, that is, it increases by 1% every 0.1S to the total throttle percentage of the original mode.

Short press the "Down" button to enter the fall angle detailed interface (return automatically after 30 seconds of no operation):

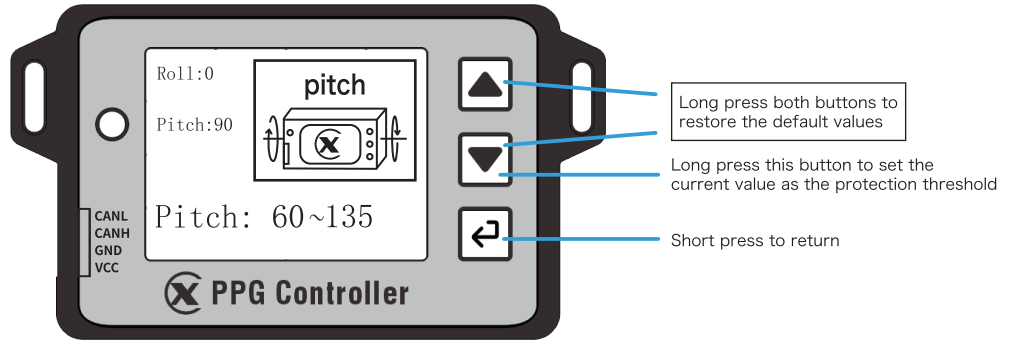

As shown in the reference figure, it is a schematic diagram showing the Euler angle. You can compare the diagram with the actual object to understand the angle definition:

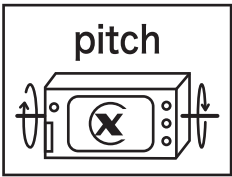
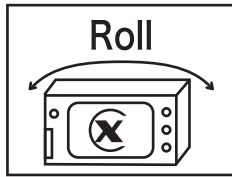
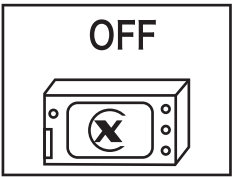
Pattern			
Explain	The default value of 90 degrees is vertical and facing the pilot. 60~135 degrees is the default safe value. If the screen is flipped upward, the angle will increase until it is horizontal (180 degrees).	The default value of 0 degrees places the user parallel to themselves. It defaults to -45~45 degrees as the safe range value. Rotate one side of the button downward to increase the degree, and rotate it in the opposite direction to decrease the degree; until the vertical position is -90 or 90 degrees.	OFF: Turn off the fall protection function
Fall angle	Pitch angle, the minimum value is fixed at 60 degrees, the maximum value setting range is 110~160 degrees.	Roll angle, the minimum setting range is -70 ~ -20, the maximum setting range is 20~70.	After the fall protection is turned off, the relevant values of this function cannot be set or changed until it is turned on again.
Fall setting	You can simulate a fall by manually flipping the screen upwards. Please refer to the angle value of Pitch during the setting process. That is, set the maximum pitch angle within the range of 110 to 160 degrees. Long press the "Down" button to set the current value to Pmax. After successful setting, it will be 60-Pmax degrees;	Please manually flip it according to the actual position to simulate a falling state. When setting, please refer to the following Roll angle value. Please set the minimum angle range of Roll within -70~-20 degrees. Press and hold the "Down" button to set the current value to Rmin. Please set the maximum angle range of Roll within 20~70 degrees. Press and hold the "Down" button to set the current value to Rmin. The current value is set to Rmax. After successful setting, the Rmin-Rmax range value can be limited;	

! : For beginners who cannot understand this Angle, it is recommended to set it to off or the default protection Angle, and do not cause the device to fail to use normally due to improper operation;

**How to restore the default:**

Please press and hold the "Up" button and the "Down" button at the same time to restore the current reference angle to the default value. Please check the corresponding setting item description for details. Short press the "Enter" button on this interface, or wait for 30 seconds without any operation and it will return to the main interface.

**7. Power**

When the power is less than 1KW, the displayed power value will be in W unit, such as: "P:800.0W". When the power is greater than 1KW, the displayed power value will be in KW unit, such as: "P:1.2KW", the screen The refresh interval is 0.3S and the displayed power is the average of the power data within three seconds.

**8. Voltage**

It displays the current voltage in "V", such as: "64.1V". When the voltage falls below the minimum voltage per cell multiplied by the number of cells, it triggers low-voltage protection. The LED light will flash, and the throttle will drop to the specified total throttle percentage value (this value is set by the user through the setting interface, such as 20% of the total throttle value). Likewise, it will also follow a slowdown ratio of 1% every 0.1S. When fully charged, it can be reset to "100%" by long pressing the "Up" button, and the corresponding low-voltage protection status will also be automatically refreshed.

**9. Current**

The displayed current value is the average current collected within 0.3S, the unit is "A", such as: "I: 100.0A"

## 4 . Wiring diagram

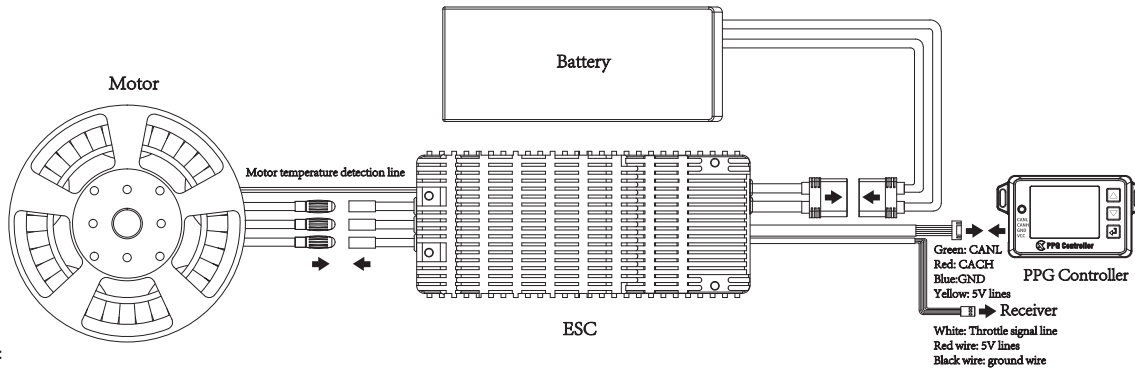

### \* Precautions:

1. Please check the positive and negative poles of the power supply, and then connect the power lines correctly.
2. If you need to use the motor temperature display, please first install the temperature sensor correctly according to the relevant ESC instructions.
3. If it is not used for more than 24 hours, it is recommended to disconnect the power lines.
4. This product is not waterproof. It is recommended to keep the wiring line clean and dry.

## 5 . Settings interface

### 1. Use page

Press and hold the "Enter" key for 2 seconds to enter the setting interface

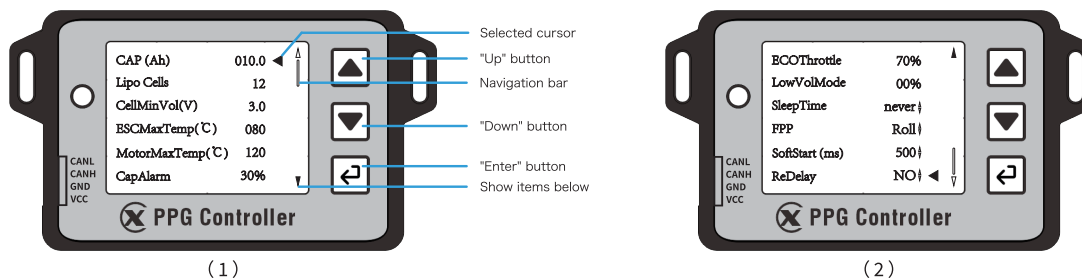

### 2.Button function

"Up" button: line selection interface, long press to exit settings

Previous line (or set value increased by 1)

"Down" button: next line (or set value decreases by 1)

"Enter" button: long press to enter/exit the project line

You can choose to increase or decrease within the current line item line

### 3. Setting items:

Items	Description	Min	Max	Default
CAP (Ah)	Effective capacity	10Ah	100.0Ah	10Ah
Lipo Cells	Effective number of battery cells	12	24	12
CellMinVol(V)	Minimum voltage per battery	2.7V	3.3V	3.0V
ESCMaTemp(°C)	ESC high temperature protection value	80°C	115°C	80°C
MotorMaTemp(°C)	Motor high temperature protection value	100°C	160°C	120°C
CapAlarm	Low battery alarm	30%	50%	30%
ECOThrottle	Eco mode setting as a percentage of total throttle	30%	80%	30%
LowVolMode	Percentage of total throttle during low voltage protection	20% (或者为0)	ECOThrottle	0%
SleepTime	Set screen inactivity time	never/15S/30S/1min/3min/5min		never
FPP	Setting the fall protection reference mode	pitch/roll/off		pitch
SoftStart(ms)	Set throttle rise delay	500/1000/1500/2000		500
ReDefault	Restore default settings	yes/no		no

**Effective capacity:** Please set it according to the actual effective capacity of the battery pack, otherwise the capacity percentage will be displayed incorrectly.

**Effective number of battery cells:** The correct number of battery cells must be set, otherwise the capacity percentage and low-voltage protection will be incorrect .

(output voltage = effective number of battery cells \* 3.7V)

**Minimum voltage of each battery:** Please set according to the actual situation, otherwise the low-voltage protection will be incorrect, and the low-voltage protection will be triggered if the voltage is lower than the low-voltage protection value (low-voltage protection value = number of valid battery packs \* minimum voltage of each battery)

**ESC high temperature protection value:** Please set it within the specified range. If it exceeds this value, the ESC high temperature protection will be triggered.

**Motor high-voltage protection value:** Please set it within the specified range. If it exceeds this value, the ESC high-temperature protection will be triggered.

(high-temperature protection recovery value = corresponding high-temperature protection value - 25°C)

**Low battery alarm:** When the battery reaches the specified value, an alarm similar to an alarm clock will be triggered. The LED light will flash and the battery capacity position will flash.

**Economic mode setting as a percentage of the total throttle:** Powerful mode is considered to be 100% throttle, and can be set within a specified range according to your needs.

**Percentage of total throttle during low voltage protection:** can be set to 0, or 20%~economic mode setting as a percentage of total throttle.

**Set the screen-free time:** You can set the automatic sleep time according to your needs. After entering the setting interface, press the "Up" button to select the previous one, and press the "Down" button to select the next one; "never": the screen will never sleep; "15S/30S/1min/3min/5min": that is, after 15S/30S/1min/3min/5 min, the device will turn off the screen backlight if there is no operation.

**Set fall protection reference mode:** Please understand the above definition of Euler angle before setting. "Pitch angle": When the PPG Controller is placed directly in front, it can be selected as the fall reference angle (default); "Roll angle": When the PPG Controller is placed on the side, it can be selected as the fall reference angle; "OFF": Turn off fall protection;

**Set the throttle rise delay:** its unit is ms. By adjusting the throttle acceleration delay, you can make the motor run softer and optimize the user experience.

**Restore default settings:** When set to yes, all setting items will be restored to their default values and then returned to no.

\*This product may undergo technical improvements or updates from time to time. If the product you purchase is different from the appearance, technical parameters, etc. described in this manual, please refer to the actual product.